

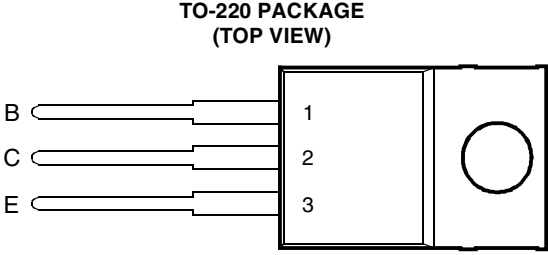

- Rugged Epitaxial Planar Construction
- 10 A Continuous Collector Current
- Operating Characteristics Fully Guaranteed at 100°C
- t_{xo} typically 320 ns, $I_C = 10$ A



Pin 2 is in electrical contact with the mounting base.
MDTRACA

absolute maximum ratings at 25°C case temperature (unless otherwise noted)

RATING		SYMBOL	VALUE	UNIT
Collector-base voltage ($I_E = 0$)	TIPL790	V_{CBO}	150	V
	TIPL790A		200	
Collector-emitter voltage ($V_{BE} = 0$)	TIPL790	V_{CES}	150	V
	TIPL790A		200	
Collector-emitter voltage ($I_B = 0$)	TIPL790	V_{CEO}	120	V
	TIPL790A		150	
Emitter-base voltage		V_{EBO}	8	V
Continuous collector current		I_C	10	A
Peak collector current (see Note 1)		I_{CM}	15	A
Continuous device dissipation at (or below) 25°C case temperature		P_{tot}	70	W
Operating junction temperature range		T_j	-65 to +150	°C
Storage temperature range		T_{stg}	-65 to +150	°C

NOTE 1: This value applies for $t_p \leq 10$ ms, duty cycle $\leq 2\%$.

PRODUCT INFORMATION

electrical characteristics at 25°C case temperature (unless otherwise noted)

PARAMETER	TEST CONDITIONS				MIN	TYP	MAX	UNIT
$V_{CEO(sus)}$ Collector-emitter sustaining voltage	$I_C = 100 \text{ mA}$	$L = 25 \text{ mH}$	(see Note 2)	TIPL790 TIPL790A	120 150			V
V_{CBO} Collector-base breakdown voltage	$I_C = 1 \text{ mA}$		(see Note 3)	TIPL790 TIPL790A	150 200			V
I_{CES} Collector-emitter cut-off current	$V_{CE} = 150 \text{ V}$ $V_{CE} = 200 \text{ V}$ $V_{CE} = 150 \text{ V}$ $V_{CE} = 200 \text{ V}$	$V_{BE} = 0$ $V_{BE} = 0$ $V_{BE} = 0$ $V_{BE} = 0$	$T_C = 100^\circ\text{C}$ $T_C = 100^\circ\text{C}$	TIPL790 TIPL790A TIPL790 TIPL790A			0.05 0.05 1 1	mA
I_{CEV} Collector cut-off current	$V_{CE} = 150 \text{ V}$ $V_{CE} = 200 \text{ V}$	$1.5 < V_{EB} < 8 \text{ V}$		TIPL790 TIPL790A			50 50	μA
I_{CEO} Collector cut-off current	$V_{CE} = 120 \text{ V}$ $V_{CE} = 150 \text{ V}$	$I_B = 0$ $I_B = 0$		TIPL790 TIPL790A			50 50	μA
I_{EBO} Emitter cut-off current	$V_{EB} = 5 \text{ V}$	$I_C = 0$					4	mA
h_{FE} Forward current transfer ratio	$V_{CE} = 5 \text{ V}$	$I_C = 0.5 \text{ A}$	(see Notes 3 and 4)		60		500	
$V_{CE(sat)}$ Collector-emitter saturation voltage	$I_B = 20 \text{ mA}$ $I_B = 30 \text{ mA}$ $I_B = 50 \text{ mA}$ $I_B = 50 \text{ mA}$	$I_C = 4 \text{ A}$ $I_C = 7 \text{ A}$ $I_C = 10 \text{ A}$ $I_C = 10 \text{ A}$	(see Notes 3 and 4) $T_C = 100^\circ\text{C}$				1.2 1.5 2.0 2.0	V
$V_{BE(sat)}$ Base-emitter saturation voltage	$I_B = 20 \text{ mA}$ $I_B = 30 \text{ mA}$ $I_B = 50 \text{ mA}$ $I_B = 50 \text{ mA}$	$I_C = 4 \text{ A}$ $I_C = 7 \text{ A}$ $I_C = 10 \text{ A}$ $I_C = 10 \text{ A}$	(see Notes 3 and 4) $T_C = 100^\circ\text{C}$				1.8 1.9 2.2 2.1	V
V_{EC} Parallel diode forward voltage	$I_E = 10 \text{ A}$	$I_B = 0$					3	V
f_t Current gain bandwidth product	$V_{CE} = 10 \text{ V}$	$I_C = 0.5 \text{ A}$	$f = 1 \text{ MHz}$ (see Note 5)			10		MHz
C_{ob} Output capacitance	$V_{CB} = 20 \text{ V}$	$I_E = 0$	$f = 0.1 \text{ MHz}$			90		pF

- NOTES: 2. Inductive loop switching measurement.
 3. These parameters must be measured using pulse techniques, $t_p = 300 \mu\text{s}$, duty cycle $\leq 2\%$.
 4. These parameters must be measured using voltage-sensing contacts, separate from the current carrying contacts.
 5. To obtain f_t the $[h_{FE}]$ response is extrapolated at the rate of -6 dB per octave from $f = 1 \text{ MHz}$ to the frequency at which $[h_{FE}] = 1$.

thermal characteristics

PARAMETER	MIN	TYP	MAX	UNIT
$R_{\theta JC}$ Junction to case thermal resistance			1.79	$^\circ\text{C/W}$

inductive-load-switching characteristics at 25°C case temperature (unless otherwise noted)

PARAMETER	TEST CONDITIONS †				MIN	TYP	MAX	UNIT
t_{si} Current storage time	$I_C = 10 \text{ A}$ $I_{B(off)} = -2.5 \text{ A}$	$I_{B(on)} = 50 \text{ mA}$ $V_{BE(off)} = -5 \text{ V}$	(see Figures 1 and 2)		450	700	ns	
t_{rv} Voltage rise time					160	750	ns	
t_{fi} Current fall time					250	400	ns	
t_{ti} Current tail time					280	450	ns	
t_{xo} Cross over time					320	500	ns	

† Voltage and current values shown are nominal; exact values vary slightly with transistor parameters.

PARAMETER MEASUREMENT INFORMATION

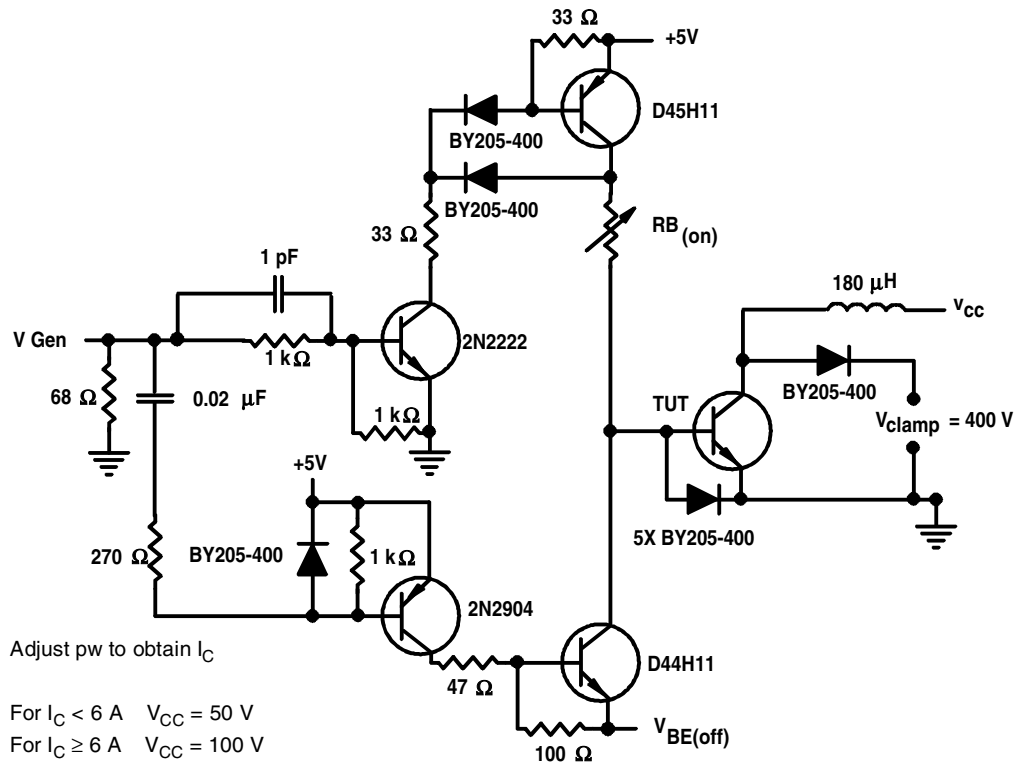
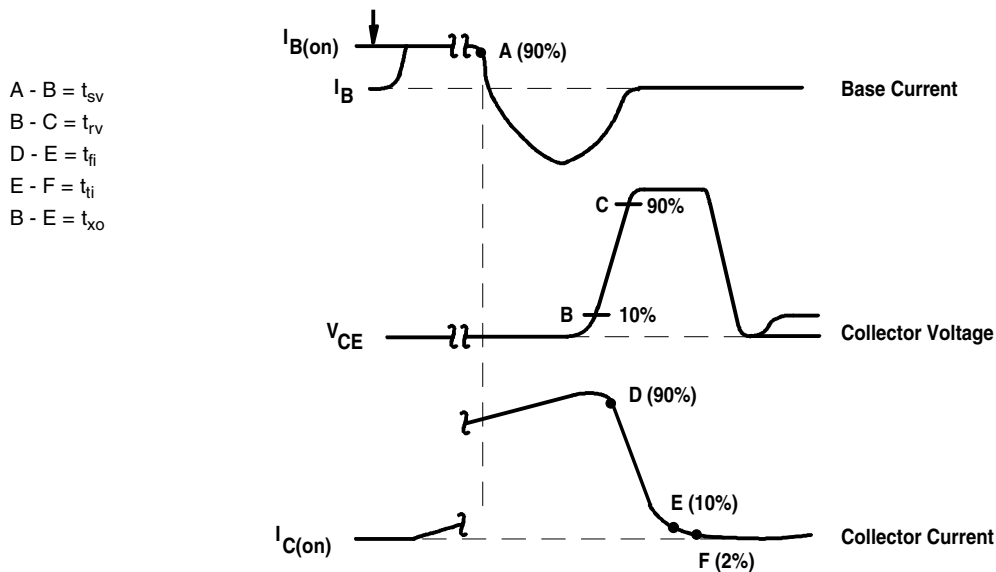

Figure 1. Inductive-Load Switching Test Circuit



NOTES: A. Waveforms are monitored on an oscilloscope with the following characteristics: $t_r < 15 \text{ ns}$, $R_{in} > 10 \Omega$, $C_{in} < 11.5 \text{ pF}$.
 B. Resistors must be noninductive types.

Figure 2. Inductive-Load Switching Waveforms

PRODUCT INFORMATION

TYPICAL CHARACTERISTICS

TYPICAL DC CURRENT GAIN
VS
COLLECTOR CURRENT

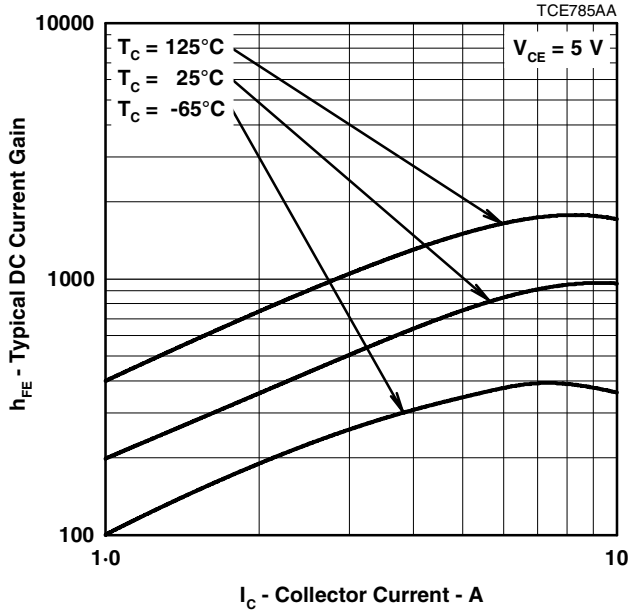

Figure 3.

COLLECTOR-EMITTER SATURATION VOLTAGE
VS
BASE CURRENT

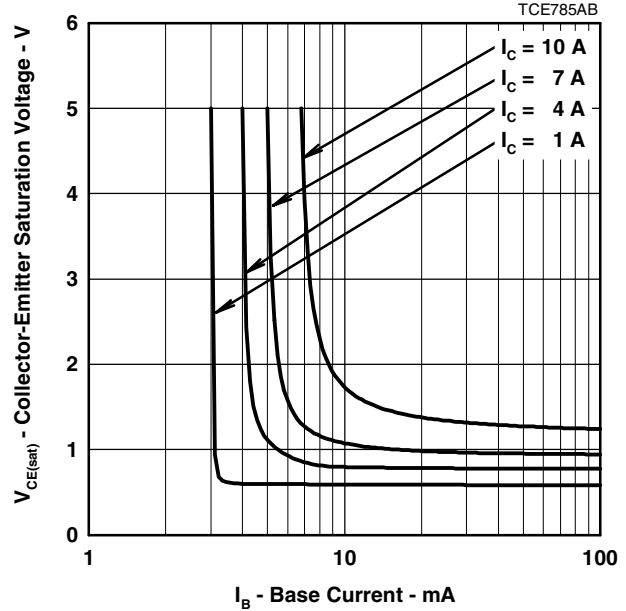

Figure 4.

BASE-EMITTER SATURATION VOLTAGE
VS
BASE CURRENT

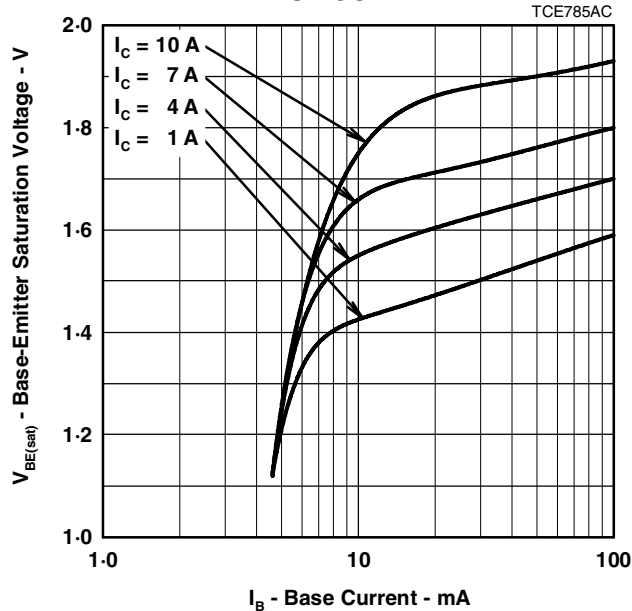

Figure 5.

COLLECTOR CUT-OFF CURRENT
VS
CASE TEMPERATURE

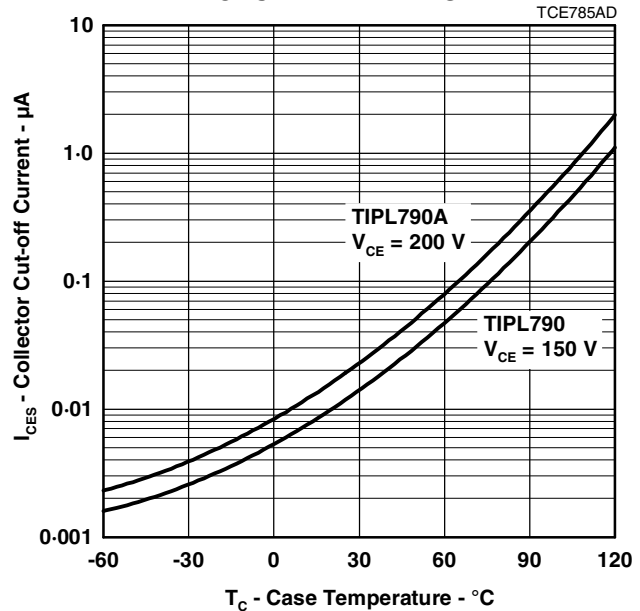

Figure 6.

PRODUCT INFORMATION

MAXIMUM SAFE OPERATING REGIONS

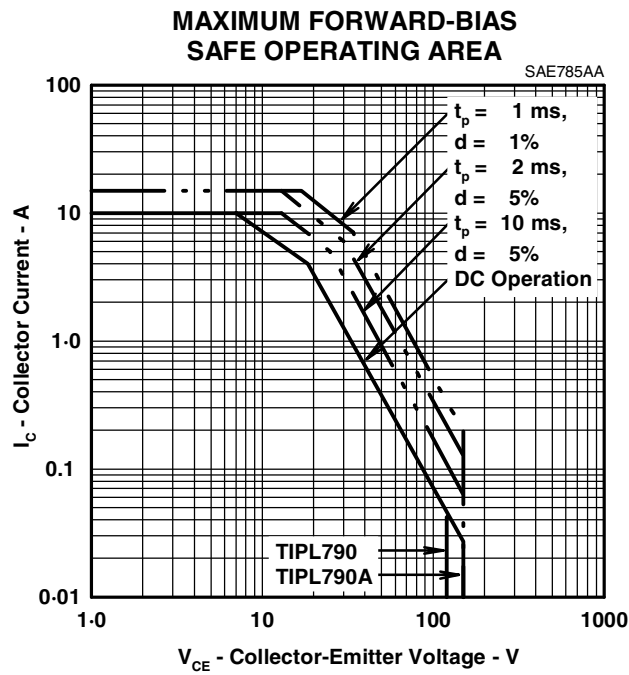

Figure 7.

PRODUCT INFORMATION

AUGUST 1978 - REVISED SEPTEMBER 2002
Specifications are subject to change without notice.

MECHANICAL DATA

TO-220

3-pin plastic flange-mount package

This single-in-line package consists of a circuit mounted on a lead frame and encapsulated within a plastic compound. The compound will withstand soldering temperature with no deformation, and circuit performance characteristics will remain stable when operated in high humidity conditions. Leads require no additional cleaning or processing when used in soldered assembly.

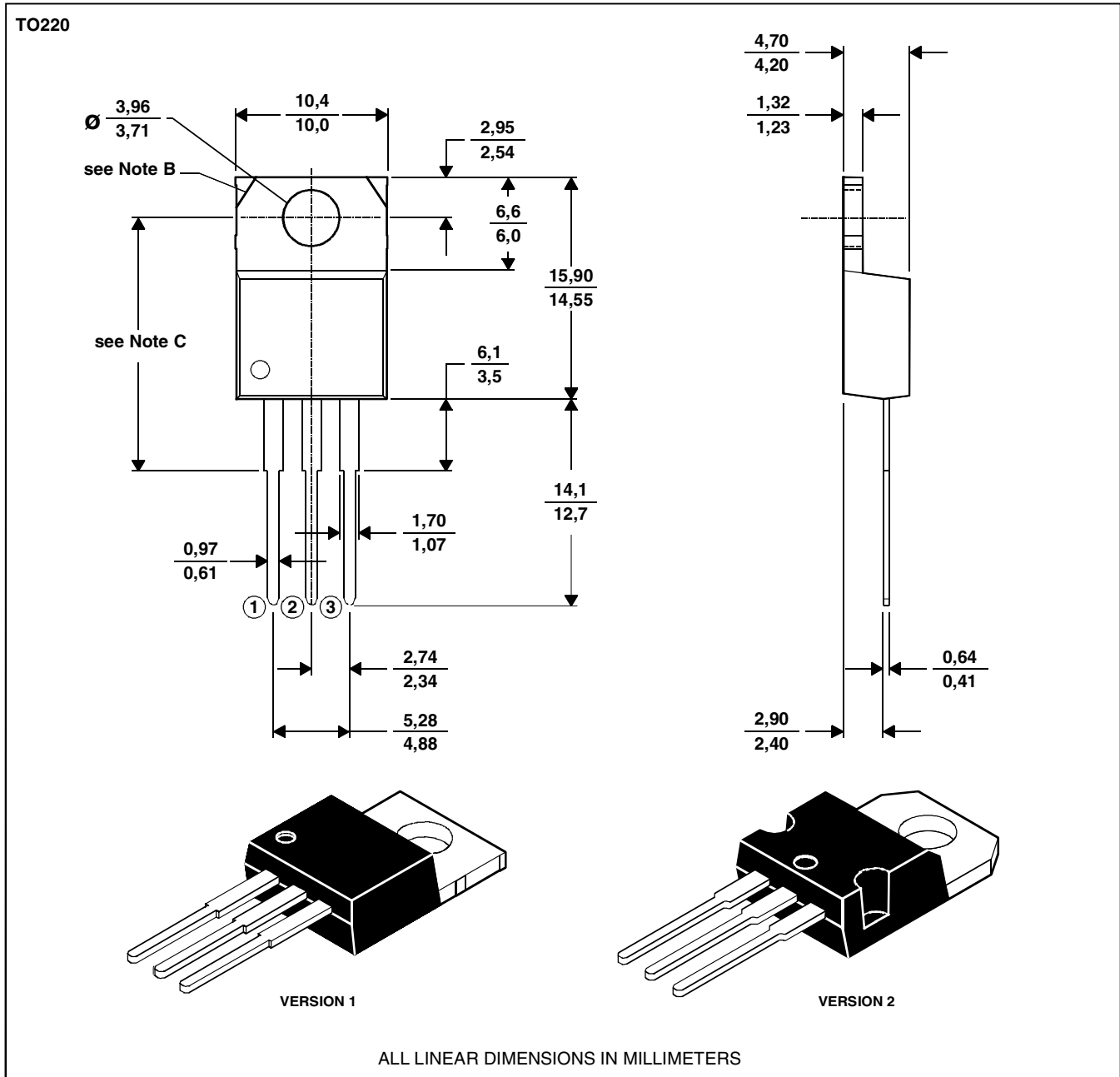

NOTES: A. The centre pin is in electrical contact with the mounting tab.
B. Mounting tab corner profile according to package version.
C. Typical fixing hole centre stand off height according to package version.
Version 1, 18.0 mm. Version 2, 17.6 mm.

MDXXBE

PRODUCT INFORMATION

AUGUST 1978 - REVISED SEPTEMBER 2002
Specifications are subject to change without notice.