



M27C64A

64 Kbit (8Kb x8) UV EPROM and OTP EPROM

Feature summary

- $5V \pm 10\%$ supply voltage in Read operation
- Access time: 100ns
- Low power "CMOS" consumption:
 - Active Current 30mA
 - Standby Current 100 μ A
- Programming voltage: $12.5V \pm 0.25V$
- High speed programming (less than 1 minute)
- Electronic signature
 - Manufacturer Code: 9Bh
 - Device Code: 08h
- ECOPACK[®] packages available

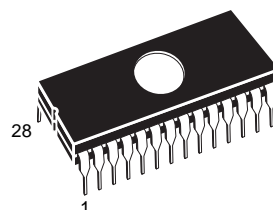

FDIP28W (F)



PLCC32 (K)

1 Summary description

The M27C64A is a 64Kbit EPROM offered in the two ranges UV (ultra violet erase) and OTP (one time programmable). It is ideally suited for microprocessor systems requiring large programs and is organized as 8,192 by 8 bits.

The FDIP28W (window ceramic frit-seal package) has transparent lid which allows the user to expose the chip to ultraviolet light to erase the bit pattern. A new pattern can then be written to the device by following the programming procedure.

For applications where the content is programmed only on time and erasure is not required, the M27C64A is offered in PLCC32 package.

In order to meet environmental requirements, ST offers the M27C64A in ECOPACK® packages.

ECOPACK packages are Lead-free. The category of second Level Interconnect is marked on the package and on the inner box label, in compliance with JEDEC Standard JESD97. The maximum ratings related to soldering conditions are also marked on the inner box label.

ECOPACK is an ST trademark. ECOPACK specifications are available at: www.st.com.

3 Maximum rating

Stressing the device above the rating listed in the Absolute Maximum Ratings table may cause permanent damage to the device. These are stress ratings only and operation of the device at these or any other conditions above those indicated in the Operating sections of this specification is not implied. Exposure to Absolute Maximum Rating conditions for extended periods may affect device reliability. Refer also to the STMicroelectronics SURE Program and other relevant quality documents.

Table 4. Absolute Maximum Ratings⁽¹⁾

Symbol	Parameter	Value	Unit
T_A	Ambient Operating Temperature ⁽³⁾	-40 to 125	°C
T_{BIAS}	Temperature Under Bias	-50 to 125	°C
T_{STG}	Storage Temperature	-65 to 150	°C
$V_{IO}^{(2)}$	Input or Output Voltage (except A9)	-2 to 7	V
V_{CC}	Supply Voltage	-2 to 7	V
$V_{A9}^{(2)}$	A9 Voltage	-2 to 13.5	V
V_{PP}	Program Supply Voltage	-2 to 14	V

1. Minimum DC voltage on Input or Output is -0.5V with possible undershoot to -2.0V for a period less than 20ns. Maximum DC voltage on Output is $V_{CC} + 0.5V$ with possible overshoot to $V_{CC} + 2V$ for a period less than 20ns.

2. Depends on range.

4 DC and AC parameters

This section summarizes the operating and measurement conditions, and the DC and AC characteristics of the device. The parameters in the DC and AC Characteristic tables that follow are derived from tests performed under the Measurement Conditions summarized in the relevant tables. Designers should check that the operating conditions in their circuit match the measurement conditions when relying on the quoted parameters.

Table 5. AC Measurement Conditions⁽¹⁾

Input Rise and Fall Times	≤20ns
Input Pulse Voltages	0.4V to 2.4V
Input and Output Timing Ref. Voltages	0.8 to 2.0V

1. Note that Output Hi-Z is defined as the point where data is no longer driven.

Figure 5. AC Testing Input Output Waveform

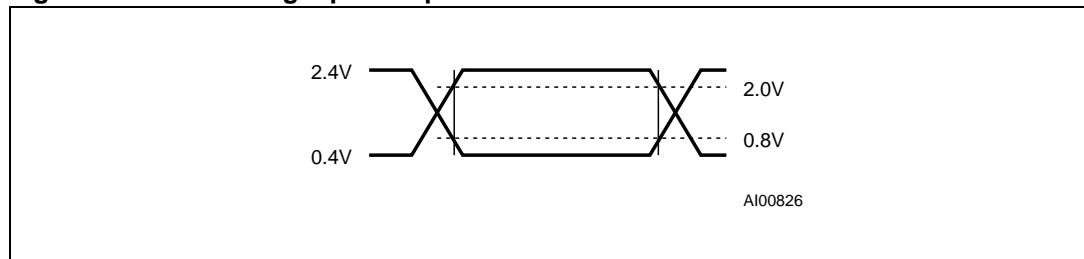

Figure 6. AC Testing Load Circuit

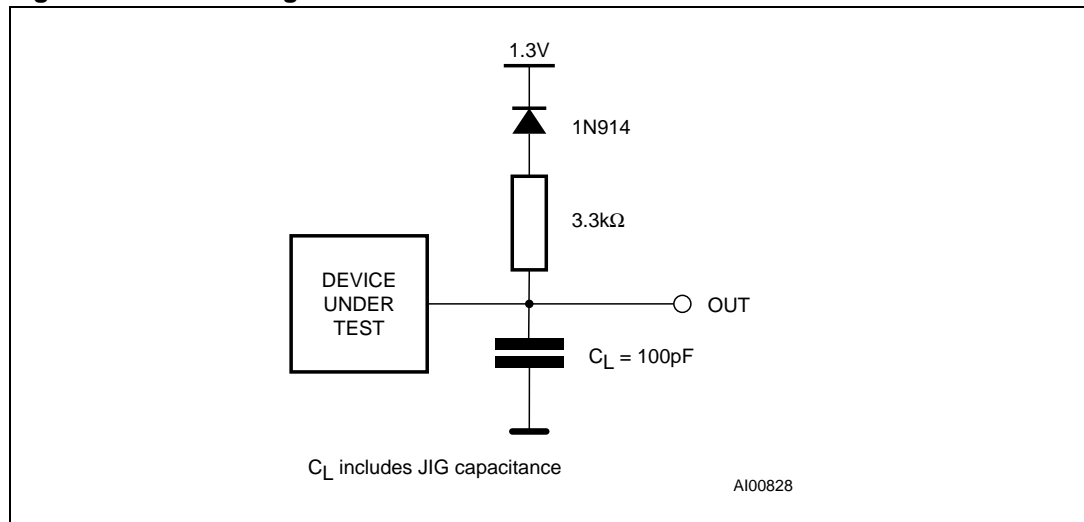

Table 6. Capacitance⁽¹⁾⁽²⁾

Symbol	Parameter	Test Condition	Min	Max	Unit
C _{IN}	Input Capacitance	V _{IN} = 0V		6	pF
C _{OUT}	Output Capacitance	V _{OUT} = 0V		12	pF

1. Sampled only, not 100% tested.

2. T_A = 25 °C, f = 1 MHz.

Table 7. Read Mode DC Characteristics⁽¹⁾⁽²⁾

Symbol	Parameter	Test Condition	Min	Max	Unit
I_{LI}	Input Leakage Current	$0V \leq V_{IN} \leq V_{CC}$		± 10	μA
I_{LO}	Output Leakage Current	$0V \leq V_{OUT} \leq V_{CC}$		± 10	μA
I_{CC}	Supply Current	$\bar{E} = V_{IL}, \bar{G} = V_{IL}, I_{OUT} = 0mA, f = 5MHz$		30	mA
I_{CC1}	Supply Current (Standby) TTL	$\bar{E} = V_{IH}$		1	mA
I_{CC2}	Supply Current (Standby) CMOS	$\bar{E} > V_{CC} - 0.2V$		100	μA
I_{PP}	Program Current	$V_{PP} = V_{CC}$		100	μA
V_{IL}	Input Low Voltage		-0.3	0.8	V
$V_{IH}^{(3)}$	Input High Voltage		2	$V_{CC} + 1$	V
V_{OL}	Output Low Voltage	$I_{OL} = 2.1mA$		0.4	V
V_{OH}	Output High Voltage TTL	$I_{OH} = -400\mu A$	2.4		V
	Output High Voltage CMOS	$I_{OH} = -100\mu A$	$V_{CC} - 0.7V$		

- $T_A = 0$ to 70 °C or -40 to 85 °C; $V_{CC} = 5V \pm 10\%$; $V_{PP} = V_{CC}$.
- V_{CC} must be applied simultaneously with or before V_{PP} and removed simultaneously or after V_{PP} .
- Maximum DC voltage on Output is $V_{CC} + 0.5V$.

Table 8. Programming Mode DC Characteristics⁽¹⁾⁽²⁾

Symbol	Parameter	Test Condition	Min	Max	Unit
I_{LI}	Input Leakage Current	$V_{IL} \leq V_{IN} \leq V_{IH}$		± 10	μA
I_{CC}	Supply Current			30	mA
I_{PP}	Program Current	$\bar{E} = V_{IL}$		30	mA
V_{IL}	Input Low Voltage		-0.3	0.8	V
V_{IH}	Input High Voltage		2	$V_{CC} + 0.5$	V
V_{OL}	Output Low Voltage	$I_{OL} = 2.1mA$		0.4	V
V_{OH}	Output High Voltage TTL	$I_{OH} = -400\mu A$	2.4		V
V_{ID}	A9 Voltage		11.5	12.5	V

- $T_A = 25$ °C; $V_{CC} = 6V \pm 0.25V$; $V_{PP} = 12.5V \pm 0.25V$.
- V_{CC} must be applied simultaneously with or before V_{PP} and removed simultaneously or after V_{PP} .

Table 9. Read Mode AC Characteristics 1⁽¹⁾⁽²⁾

Symbol	Alt	Parameter	Test Condition	M27C64A						Unit
				-10		-15		-20		
				Min	Max	Min	Max	Min	Max	
t_{AVQV}	t_{ACC}	Address Valid to Output Valid	$\bar{E} = V_{IL}, \bar{G} = V_{IL}$		100		150		200	ns
t_{ELQV}	t_{CE}	Chip Enable Low to Output Valid	$\bar{G} = V_{IL}$		100		150		200	ns
t_{GLQV}	t_{OE}	Output Enable Low to Output Valid	$\bar{E} = V_{IL}$		50		75		80	ns
$t_{EHQZ}^{(3)}$	t_{DF}	Chip Enable High to Output Hi-Z	$\bar{G} = V_{IL}$	0	50	0	50	0	50	ns
$t_{GHQZ}^{(3)}$	t_{DF}	Output Enable High to Output Hi-Z	$\bar{E} = V_{IL}$	0	50	0	50	0	50	ns
t_{AXQX}	t_{OH}	Address Transition to Output Transition	$\bar{E} = V_{IL}, \bar{G} = V_{IL}$	0		0		0		ns

1. $T_A = 0$ to $70\text{ }^\circ\text{C}$ or -40 to $85\text{ }^\circ\text{C}$; $V_{CC} = 5V \pm 10\%$; $V_{PP} = V_{CC}$.
2. V_{CC} must be applied simultaneously with or before V_{PP} and removed simultaneously or after V_{PP} .
3. Sampled only, not 100% tested.

Table 10. Read Mode AC Characteristics 2⁽¹⁾⁽²⁾

Symbol	Alt	Parameter	Test Condition	M27C64A				Unit
				-25		-30		
				Min	Max	Min	Max	
t_{AVQV}	t_{ACC}	Address Valid to Output Valid	$\bar{E} = V_{IL}, \bar{G} = V_{IL}$		250		300	ns
t_{ELQV}	t_{CE}	Chip Enable Low to Output Valid	$\bar{G} = V_{IL}$		250		300	ns
t_{GLQV}	t_{OE}	Output Enable Low to Output Valid	$\bar{E} = V_{IL}$		100		120	ns
$t_{EHQZ}^{(3)}$	t_{DF}	Chip Enable High to Output Hi-Z	$\bar{G} = V_{IL}$	0	60	0	105	ns
$t_{GHQZ}^{(3)}$	t_{DF}	Output Enable High to Output Hi-Z	$\bar{E} = V_{IL}$	0	60	0	105	ns
t_{AXQX}	t_{OH}	Address Transition to Output Transition	$\bar{E} = V_{IL}, \bar{G} = V_{IL}$	0		0		ns

1. $T_A = 0$ to $70\text{ }^\circ\text{C}$ or -40 to $85\text{ }^\circ\text{C}$; $V_{CC} = 5V \pm 10\%$; $V_{PP} = V_{CC}$.
2. V_{CC} must be applied simultaneously with or before V_{PP} and removed simultaneously or after V_{PP} .
3. Sampled only, not 100% tested.

Table 11. Programming Mode AC Characteristics⁽¹⁾⁽²⁾

Symbol	Alt	Parameter	Test Condition	Min	Max	Unit
t_{AVPL}	t_{AS}	Address Valid to Program Low		2		μs
t_{QVPL}	t_{DS}	Input Valid to Program Low		2		μs
t_{VPHPL}	t_{VPS}	V_{PP} High to Program Low		2		μs
t_{VCHPL}	t_{VCS}	V_{CC} High to Program Low		2		μs
t_{ELPL}	t_{CES}	Chip Enable Low to Program Low		2		μs
t_{PLPH}	t_{PW}	Program Pulse Width (Initial)		0.95	1.05	ms
		Program Pulse Width (Over Program)		2.85	78.75	ms
t_{PHQX}	t_{DH}	Program High to Input Transition		2		μs
t_{QXGL}	t_{OES}	Input Transition to Output Enable Low		2		μs
t_{GLQV}	t_{OE}	Output Enable Low to Output Valid			100	ns
$t_{GHQZ}^{(3)}$	t_{DFP}	Output Enable High to Output Hi-Z		0	130	ns
t_{GHAX}	t_{AH}	Output Enable High to Address Transition		0		ns

1. $T_A = 25\text{ }^\circ\text{C}$; $V_{CC} = 6V \pm 0.25V$; $V_{PP} = 12.5V \pm 0.25V$.
2. V_{CC} must be applied simultaneously with or before V_{PP} and removed simultaneously or after V_{PP} .
3. Sampled only, not 100% tested.

Figure 8. Programming and Verify Modes AC Waveforms

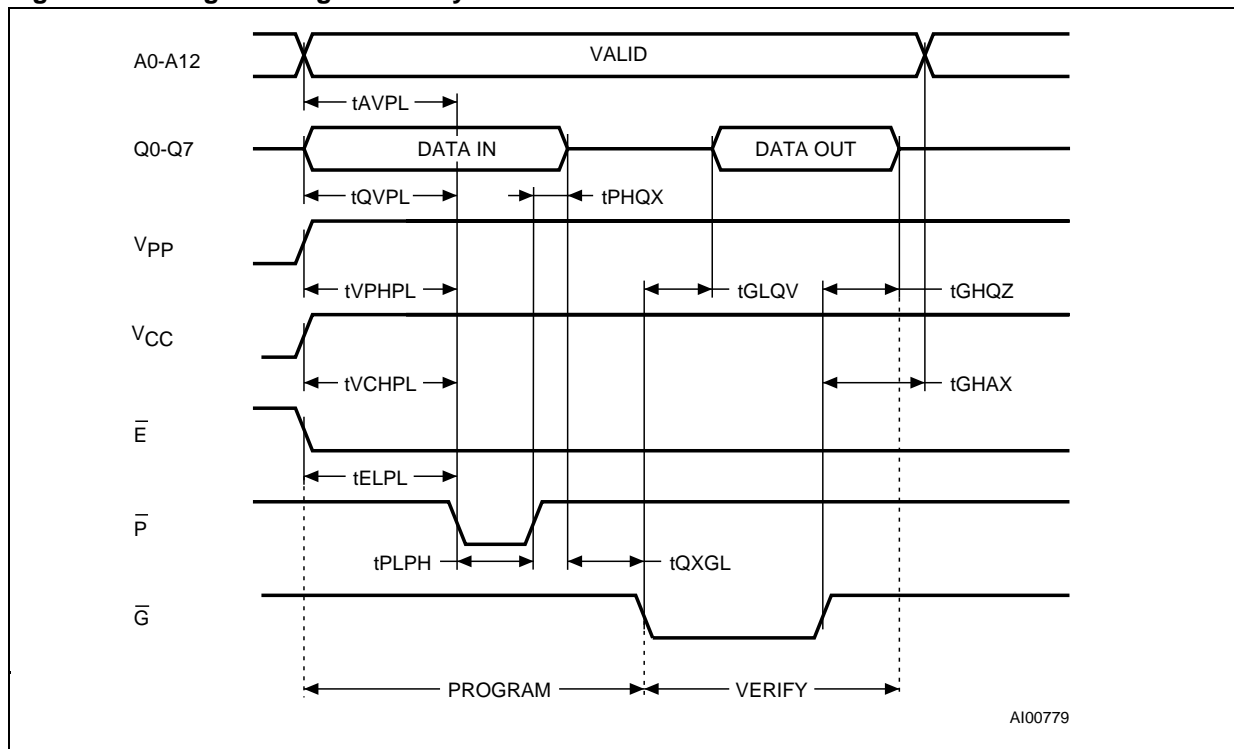

5 Package mechanical data

Figure 9. FDIP28W - 28 pin Ceramic Frit-seal DIP, with window, Package Outline

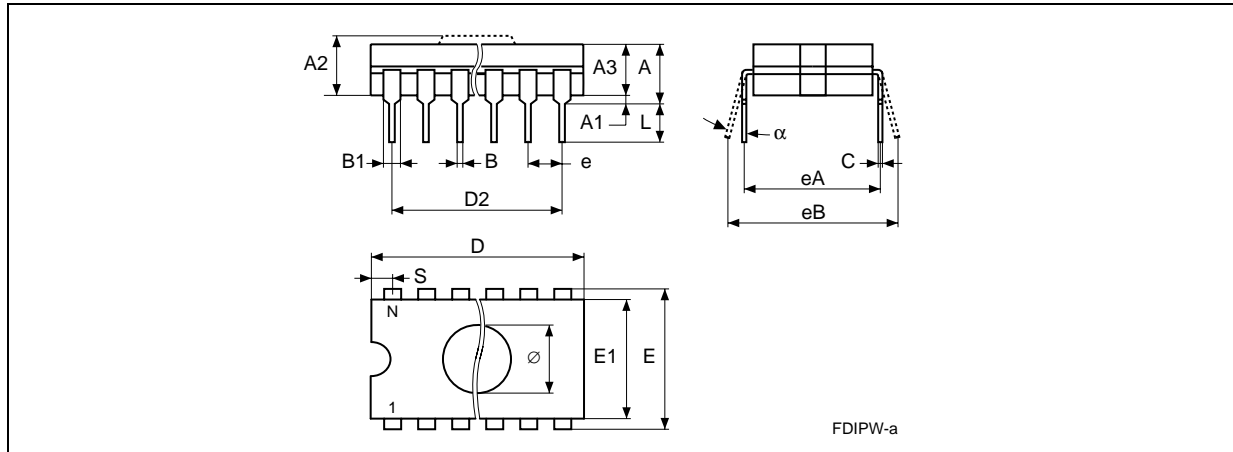

1. Drawing is not to scale.

Table 12. FDIP28W - 28 pin Ceramic Frit-seal DIP, with window, Package Mechanical Data

Symbol	millimeters			inches			
	Typ	Min	Max	Typ	Min	Max	
A			5.72			0.225	
A1		0.51	1.40		0.020	0.055	
A2		3.91	4.57		0.154	0.180	
A3		3.89	4.50		0.153	0.177	
B		0.41	0.56		0.016	0.022	
B1	1.45	–	–	0.057	–	–	
C		0.23	0.30		0.009	0.012	
D		36.50	37.34		1.437	1.470	
D2	33.02	–	–	1.300	–	–	
E	15.24	–	–	0.600	–	–	
E1		13.06	13.36		0.514	0.526	
e	2.54	–	–	0.100	–	–	
eA	14.99	–	–	0.590	–	–	
eB		16.18	18.03		0.637	0.710	
L		3.18	4.10		0.125	0.161	
S		1.52	2.49		0.060	0.098	
∅	7.11	–	–	0.280	–	–	
α		4°	11°		4°	11°	
N		28				28	

6 Part numbering

Table 14. Ordering Information Scheme

Example:	M27C64A	-10	K	1
Device Type	M27			
Supply Voltage	C = 5V ±10%			
Device Function	64A = 64 Kbit (8Kb x8)			
Speed	-10 = 100 ns -15 = 150 ns -20 = 200 ns -25 = 250 ns -30 = 300 ns			
Package	F = FDIP28W K = PLCC32			
Temperature Range	1 = 0 to 70 °C 6 = -40 to 85 °C			

For a list of available options (Speed, Package, etc...) or for further information on any aspect of this device, please contact the STMicroelectronics Sales Office nearest to you.